

todobarro.

handcrafted lattices

CATALOGUE



tb.

The footprint of artisanship

Indoors, they separate while decorating, letting light and air pass through. Outdoors, they become a bioclimatic element capable of promoting cross-ventilation and regulating indoor temperature. At todobarro, however, we believe that breeze blocks can also take center stage, becoming the defining element of any type of space.

That is why our proposal brings together two aspects that rarely coincide:

- **A genuinely artisanal process.** Each piece is extruded, cut, and finished by hand using local clays. Its Antique finish—aged and silky—enhances the subtle variations resulting from this process.

- **A modular system.** Each model fits into a 12-centimeter grid that makes all the formats and accessories in this catalog compatible with each other. This gives rise to endless designs, which our specialized advisory team will help you adapt to your project.

The system can be enriched with two planter models and birdhouses. This is our commitment to creating living breeze blocks, beneficial both for people and for the environment, whose beauty—like that of our pieces—evolves with the passing of time.



Index

Handcrafted lattice panels

Place your order in
our online store



Málaga 12

12×12×8 cm



Málaga 24

24×12×8 cm



Ronda 12

12×12×8 cm



Ronda 24

24×12×8 cm



Cañizo

24×12×8 cm



Vélez

12×12×8 cm



Casares

24×12×8 cm



Ojén

12×12×8 cm

Available colors

All lattice panels are available
in three colors:

 Rojizo  Pizarra  Blanco

Index

Lattice panel accessories

Place your order in
our online store



Planter 12
24×12×12 cm



Planter 24
24×24×12 cm



Birdhouse 12
24×12×12 cm



Birdhouse 24
24×24×12 cm

Available colors

All lattice panels are available
in three colors:

 Rojizo  Pizarra  Blanco

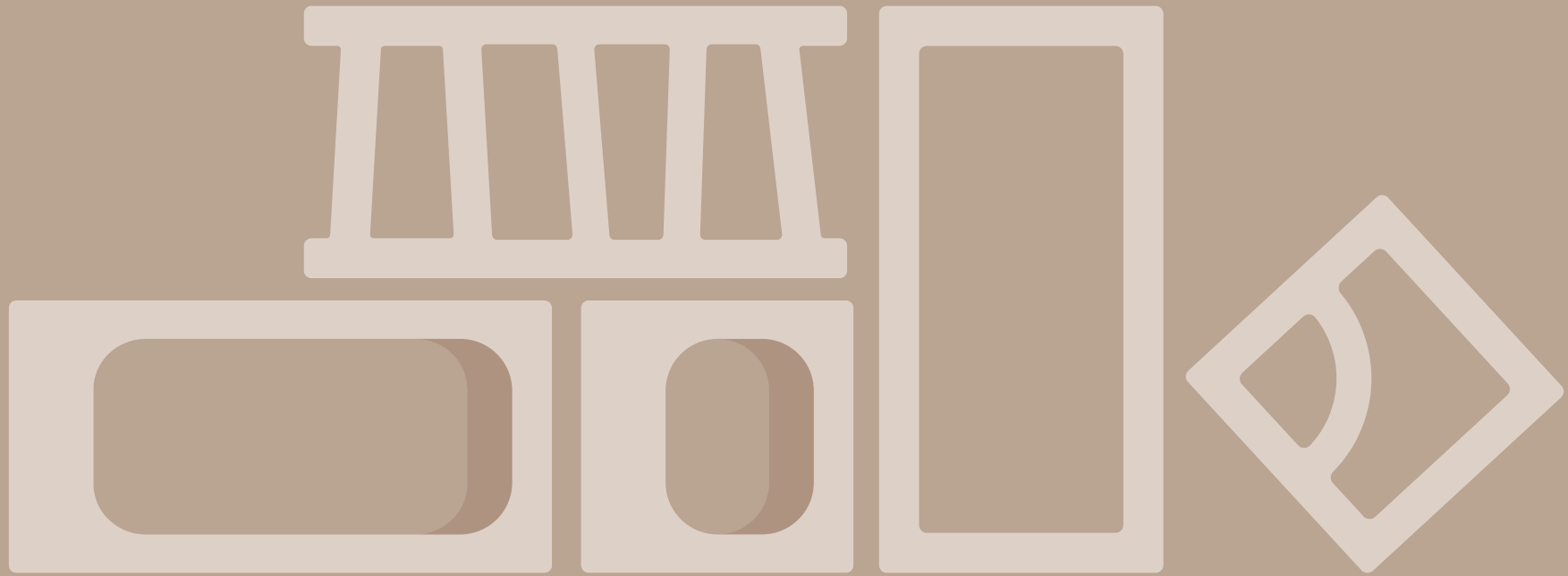

a modular system where everything fits perfectly

Each model in this system fits into a **12-centimeter grid**, making all the pieces compatible with each other. This offers several advantages:

1. Flexibility in compositions: Select the combination of pieces that best fits your project or create custom walls by mixing different models.

2. Maintenance and versatility: Any module can be independently removed and replaced.

3. Accessory integration: Accessories in this collection can be incorporated into the system regardless of the model used.



Lattices – Málaga Model Combination
Reddish Tone

MODULAR LATTICE

málaga

This collection is the essential foundation of the entire tobarro screen blocks system. Available in 12×12 and 24×12 formats, it allows for customized grids and rhythms that adapt to the needs of each project.

Available colors:



Málaga 12

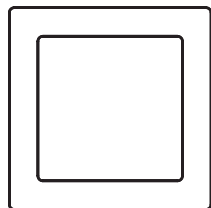

Málaga 24

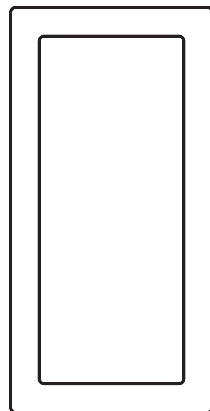



Lattices – Málaga Model Combination
Blanco Antiquo with 4mm grouting



Lattices - Málaga 24
Reddish Tone





Lattices – Málaga Model Combination
Pizarra with 4mm grouting



Lattices – Málaga Model Combination
pizarra with 8mm grouting

TECHNICAL INFORMATION

málaga

All our screen blocks are handcrafted and finished by hand, which may result in slight dimensional tolerances between pieces, especially among blocks in different colours.

In addition, each piece may present subtle tonal variations, resulting from the unique characteristics of each clay body and the firing process.

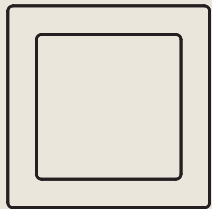

Málaga 12



Sizes

BARRO ROJIZO | PIZARRA
12,1×12,1×8 cm

BARRO BLANCO
12,3×12,3×8 cm



Yield for 4 mm grout joint

BARRO ROJIZO | PIZARRA
64 piezas/m²

BARRO BLANCO
62 piezas/m²



Weight

1,3 kg/ud
83,2 kg/m²

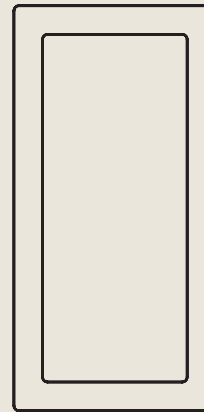

Málaga 24



Sizes

BARRO ROJIZO | PIZARRA
24,2×12,1×8 cm

BARRO BLANCO
24,6×12,3×8 cm



Yield for 4 mm grout joint

BARRO ROJIZO | PIZARRA
33 piezas/m²

BARRO BLANCO
32 piezas/m²



Weight

1,98 kg/ud
83,2 kg/m²

vélez

Like the Vélez tile collection, this model designed by Leblume is also inspired by the handcrafted heritage of traditional terracotta from the Axarquía and by the semicircular arch. Their design makes it possible to create organic patterns through the arrangement and rotation of each piece, allowing structured or fluid compositions to emerge from a single element.

Designed by Carlos Jiménez and Damián López (Leblume)

Available colors:



Vélez 12

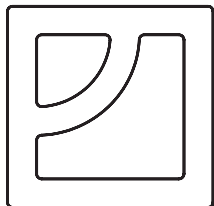



Lattice - Vélez with Planter 12
Reddish Tone



Lattice - Vélez 12
Reddish Tone



Lattice - Vélez
Blanco Antiguo with 4mm grouting

TECHNICAL INFORMATION

vélez

All our screen blocks are handcrafted and finished by hand, which may result in slight dimensional tolerances between pieces, especially among blocks in different colours.

In addition, each piece may present subtle tonal variations, resulting from the unique characteristics of each clay body and the firing process.

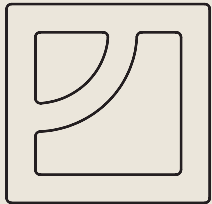

Vélez 12



Sizes

BARRO ROJIZO | PIZARRA
12,1×12,1×8 cm

BARRO BLANCO
12,3×12,3×8 cm



Yield for 4 mm grout joint

BARRO ROJIZO | PIZARRA
64 piezas/m²

BARRO BLANCO
62 piezas/m²



Weight

1,5 kg/ud

96 kg/m²

tb.

custom creations

The modularity of our system offers the freedom to create designs tailored to your project using the six available blocks models. These possibilities expand even further with the addition of two planter formats and birdhouses.

Lattices



cañizo

Inspired by the reed screens that filter light in Mediterranean courtyards, this rhythmic and organic screen block design is the continuation of its counterpart in the zellige collection. The pieces are available in a 24×12 cm format.

Available colors:



Cañizo

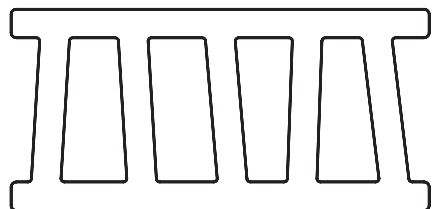



Lattice - Cañizo
Reddish Tone



Lattice - Cañizo
Reddish Tone



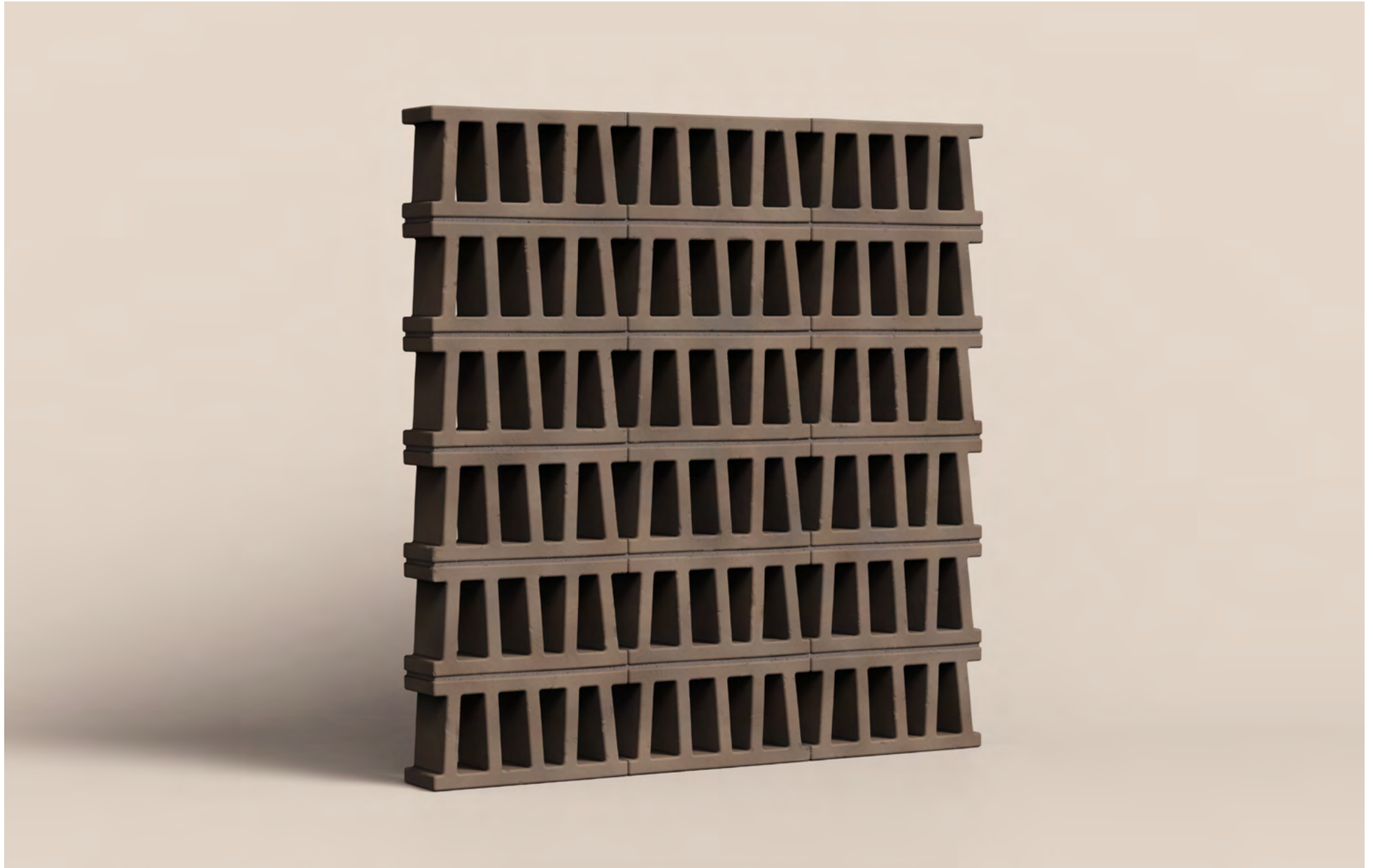

Lattice - Cañizo
Pizarra with 4mm grouting

TECHNICAL INFORMATION

cañizo

All our screen blocks are handcrafted and finished by hand, which may result in slight dimensional tolerances between pieces, especially among blocks in different colours.

In addition, each piece may present subtle tonal variations, resulting from the unique characteristics of each clay body and the firing process.

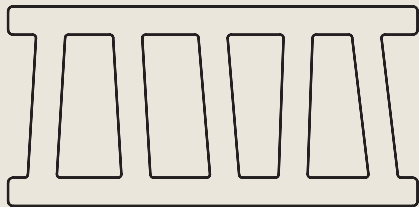

Vélez 12



Sizes

BARRO ROJIZO | PIZARRA
12,1×12,1×8 cm

BARRO BLANCO
12,3×12,3×8 cm



Yield for 4 mm grout joint

BARRO ROJIZO | PIZARRA
32 piezas/m²

BARRO BLANCO
32 piezas/m²



Weight

2,5 kg/ud

80 kg/m²

ronda

A screen block designed by Carlos Jiménez and Leblume featuring an innovative oblique opening. This characteristic makes it possible to create shifting rhythms, visually dynamic walls, and playful effects with visibility depending on the point of view.

Designed by Carlos Jiménez and Damián López (Leblume)

Available colors:



Ronda 12

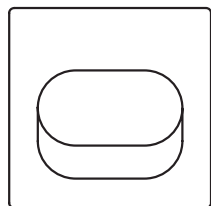

Ronda 24

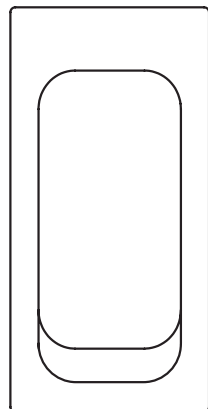



Lattice - Ronda Model Combination
Rojiza with 4mm grouting



Lattice - Ronda Model Combination
Reddish Tone



Lattice - Ronda 12
Blanco antiguo with 4mm grouting



Lattice - Ronda 12
Blanco antiguo with 8mm grouting

TECHNICAL INFORMATION

ronda

All our screen blocks are handcrafted and finished by hand, which may result in slight dimensional tolerances between pieces, especially among blocks in different colours.

In addition, each piece may present subtle tonal variations, resulting from the unique characteristics of each clay body and the firing process.

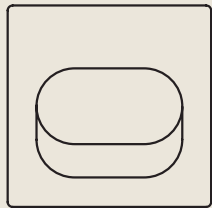

Ronda 12



Sizes

BARRO ROJIZO | PIZARRA
12,1×12,1×8 cm

BARRO BLANCO
12,3×12,3×8 cm



Yield for 4 mm grout joint

BARRO ROJIZO | PIZARRA
64 piezas/m²

BARRO BLANCO
62 piezas/m²



Weight

1,55 kg/ud
99,2 kg/m²

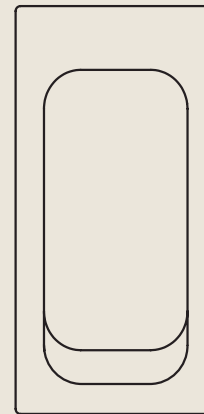

Ronda 24



Sizes

BARRO ROJIZO | PIZARRA
24,2×12,1×8 cm

BARRO BLANCO
24,6×12,3×8 cm



Yield for 4 mm grout joint

BARRO ROJIZO | PIZARRA
33 piezas/m²

BARRO BLANCO
32 piezas/m²



Weight

2,3 kg/ud
73,6 kg/m²

ojén

Designed by Jorge Herrera Studio, this 12×12 piece is unique in both composition and form. Its circular hollow widens as it approaches the outer face of the block, creating a gradient effect that softens the shadow and filters the light passing through it.

Designed by Jorge Herrera Studio

Available colors:



Ojén

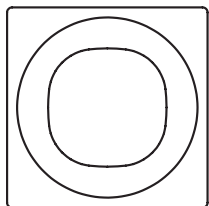

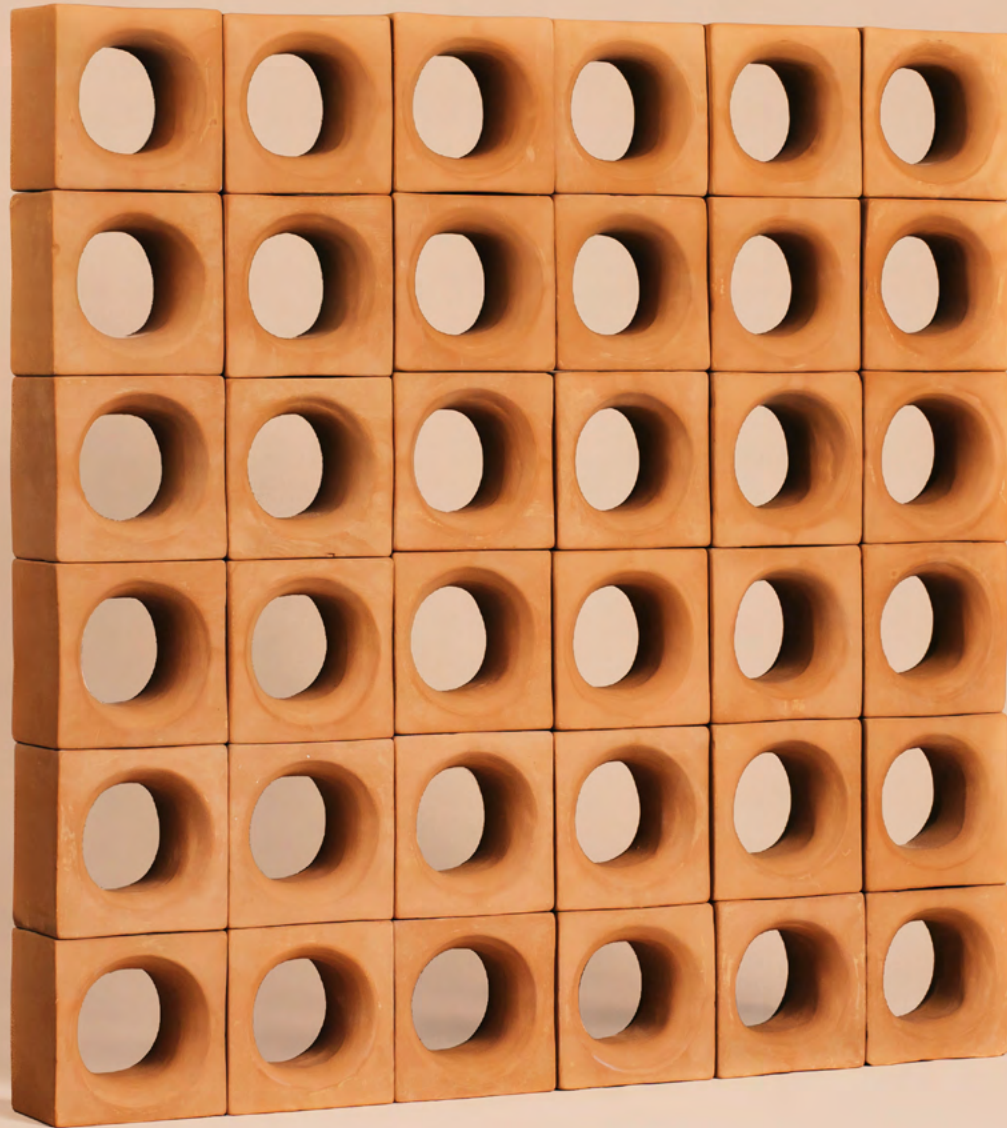

Lattice - Ojén
Reddish Tone

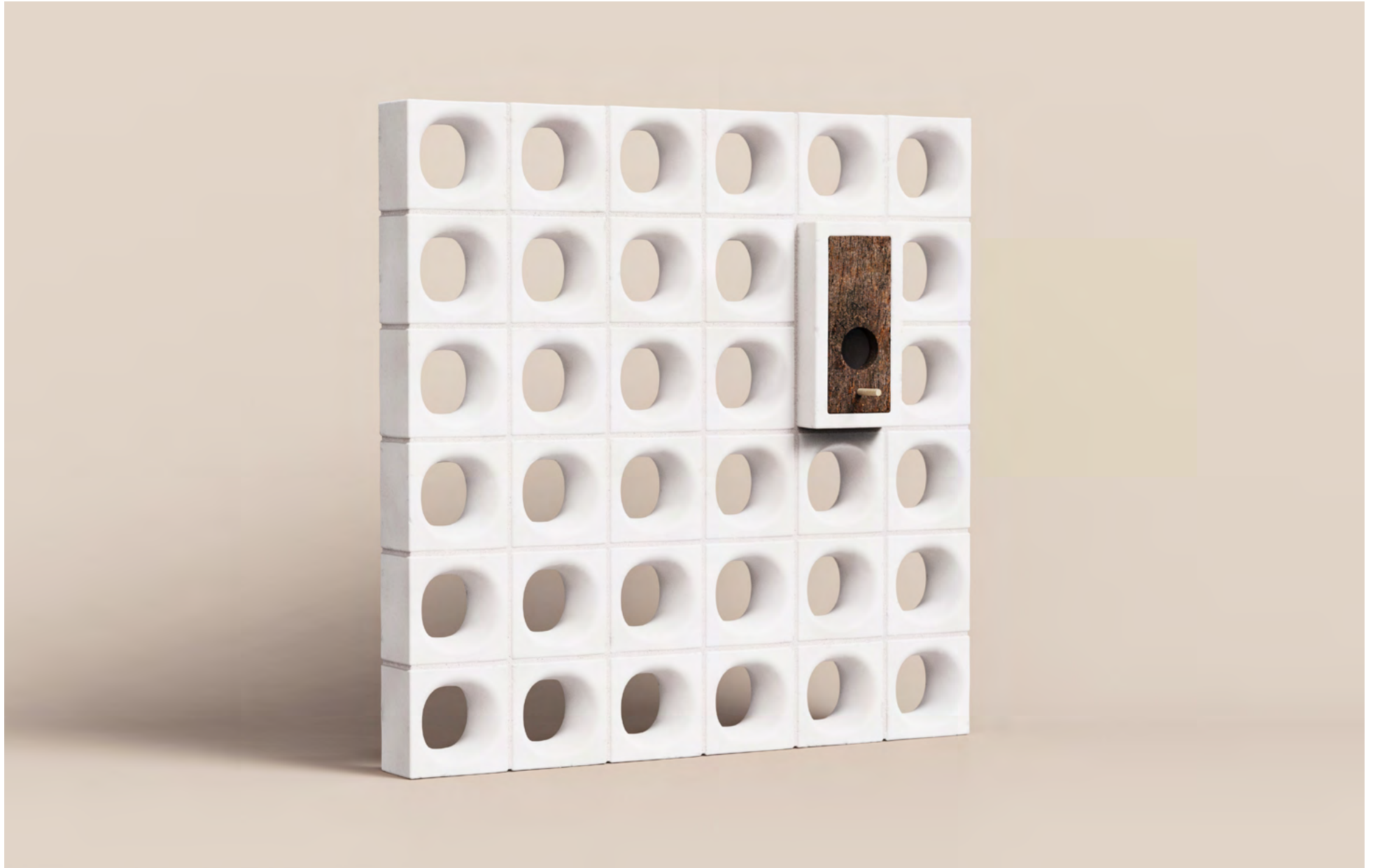

Lattice - Ojén
Blanco antiguo with 4mm grouting

TECHNICAL INFORMATION

ojén

All our screen blocks are handcrafted and finished by hand, which may result in slight dimensional tolerances between pieces, especially among blocks in different colours.

In addition, each piece may present subtle tonal variations, resulting from the unique characteristics of each clay body and the firing process.

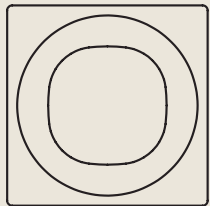

Ronda 12



Sizes

BARRO ROJIZO | PIZARRA
12,1×12,1×8 cm

BARRO BLANCO
12,3×12,3×8 cm



Yield for 4 mm grout joint

BARRO ROJIZO | PIZARRA
64 piezas/m²

BARRO BLANCO
62 piezas/m²



Weight

1,62 kg/ud

103,7 kg/m²

casares

This piece plays with the pronounced inclination of its two inner walls. This feature allows for versatile placement, guiding the view of spaces and even creating openings that encourage natural airflow.

Designed by Carlos Jiménez and Damián López (Leblume)

Available colors:



Casares

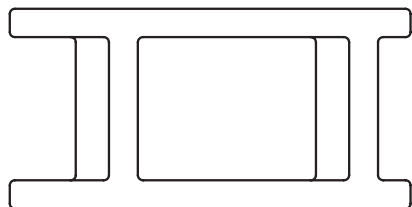



Lattice - Casares
Pizarra with 4mm grouting



Lattice - Casares
Reddish Tone



TECHNICAL INFORMATION

casares

All our screen blocks are handcrafted and finished by hand, which may result in slight dimensional tolerances between pieces, especially among blocks in different colours.

In addition, each piece may present subtle tonal variations, resulting from the unique characteristics of each clay body and the firing process.

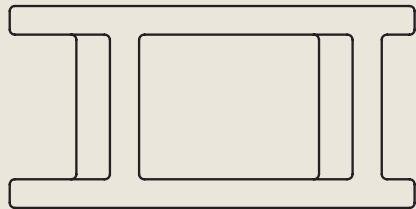

Casares



Sizes

BARRO ROJIZO | PIZARRA
24,2×12,1×8 cm

BARRO BLANCO
24,6×12,3×8 cm



Yield for 4 mm grout joint

BARRO ROJIZO | PIZARRA
32 piezas/m²

BARRO BLANCO
32 piezas/m²



Weight

1,8 kg/ud

57,6 kg/m²



tb.

made for the eye, and for the touch

All our breeze blocks are finished with our exclusive Antique texture, a controlled aging process that wears down and softens the surface. The resulting pieces, with their silky touch and subtle tonal variations, evoke the essence of traditional terracotta.

Lattices

planter

The planters in this collection evoke the Mediterranean tradition of combining terracotta and greenery to create fresh, vibrant, and healthy spaces. When integrated into the blocks system, they enhance the overall thermal comfort of the composition.

Macetero 12

 24×12×12

 3,4 kg/ud

Macetero 24

 24×24×12

 4,9 kg/ud

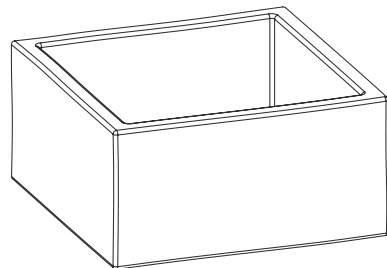
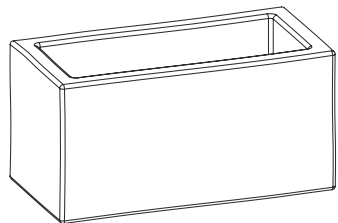







Lettice - Málaga 12
White shade with planter 12





birdhouse

Birdhouses not only bring a natural touch to the space by adding extra biodiversity, but they also add an acoustic dimension to the project — a natural soundtrack.

Birdhouse 12

 24×12×12
 3,8 kg/ud

Birdhouse 24

 24×24×12
 5,5 kg/ud

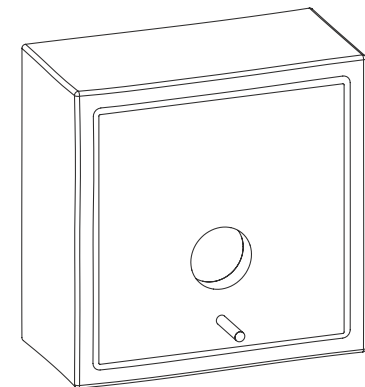
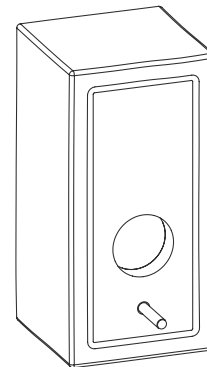



Lattice - Ronda 24 with birdhouse 24
Pizarra with 4mm grouting



Lattice - Birdhouse 12
Reddish Tone

Rates

Lattice accessories

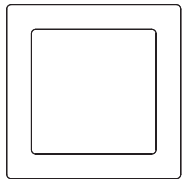

Málaga 12

Color	Nombre	€/ud	€/m ²
●	Rojiza	3,20	205
●	Pizarra	3,20	205
●	Blanco	3,44	220

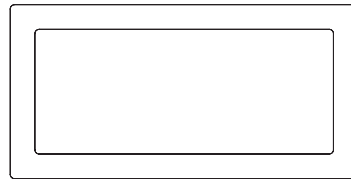

Málaga 24

Color	Nombre	€/ud	€/m ²
●	Rojiza	5,47	175
●	Pizarra	5,47	175
●	Blanco	5,59	179

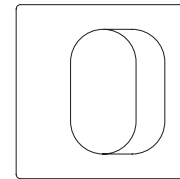

Ronda 12

Color	Nombre	€/ud	€/m ²
●	Rojiza	5,70	365
●	Pizarra	5,70	365
●	Blanco	5,86	375

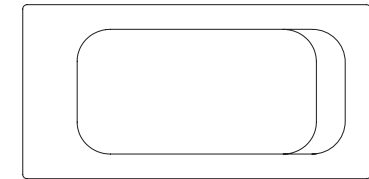

Ronda 24

Color	Nombre	€/ud	€/m ²
●	Rojiza	6,84	219
●	Pizarra	6,84	219
●	Blanco	7,03	225

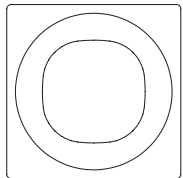

Ojén

Color	Nombre	€/ud	€/m ²
●	Rojiza	6,80	435
●	Pizarra	6,80	435
●	Blanco	6,95	445

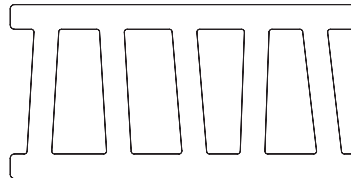

Cañizo

Color	Nombre	€/ud	€/m ²
●	Rojiza	6,41	205
●	Pizarra	6,41	205
●	Blanco	6,72	215

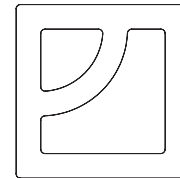

Vélez

Color	Nombre	€/ud	€/m ²
●	Rojiza	3,52	225
●	Pizarra	3,52	225
●	Blanco	3,67	235

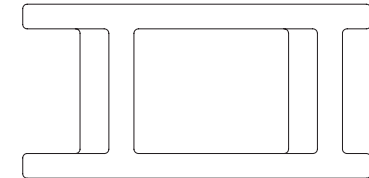

Casares

Color	Nombre	€/ud	€/m ²
●	Rojiza	6,84	219
●	Pizarra	6,84	219
●	Blanco	7,03	225

todobarro.com

**place your order
in our online
store**



Rates

Lattice accessories

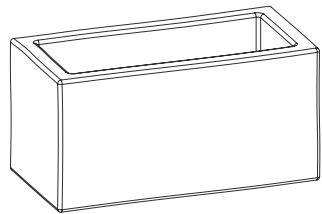

Macetero 12

Color	Nombre	€/ud
●	Rojiza	10
●	Pizarra	10
●	Blanco	11

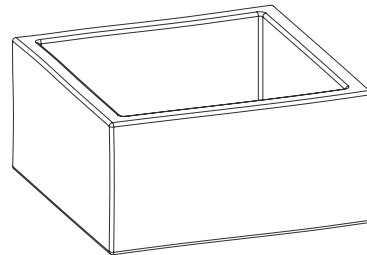

Macetero 24

Color	Nombre	€/ud
●	Rojiza	14
●	Pizarra	14
●	Blanco	15

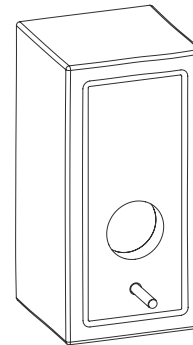

Casa para Pájaros 12

Coming soon

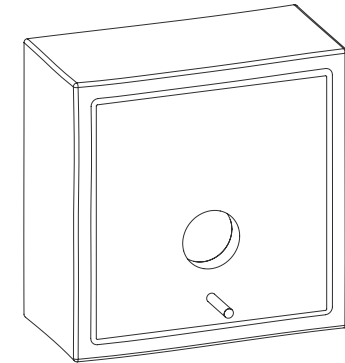

Casa para Pájaros 24

Coming soon

todobarro.com

**place your order
in our online
store**



Services and specifications



Production time

Artisanal lattices require between **50 and 70 days** of production from the date the order is confirmed. This period may be shortened or extended depending on weather conditions that affect the material's drying time.

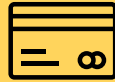

Order confirmation

An initial payment of 50% of the quoted amount is required by bank transfer, with the remaining 50% due upon delivery. For international deliveries, 100% of the amount must be paid before the order leaves the workshop.

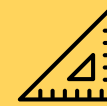

Technical Office

Our team of advisors and technicians will guide you through the solutions best suited to your project.



ISO Certification

We are ISO 9001 certified, a standard designed to improve customer trust and satisfaction, foster a proactive culture of prevention, improvement, and environmental protection, and ensure the quality of our products and services.



Contact

Business Hours

Monday to Friday
9:00 AM to 6:00 PM

Phone and Email

+34 951 551 051
+34 670 676 026
info@todobarro.com

Follow us



Technical Office

Plaza Poeta Alfonso Canales 4,
Planta 1ª, Oficina 3, 29001 Málaga

todobarro.

46

info@todobarro.com
+34 951 551 051

Pl. Poeta Alfonso Canales, 4
29001 Málaga

todobarro.com